

**MODEL:306015T**

**W9.15xL18.3xH4.5M**

**ASSEMBLE MANUAL**

**Congratulations** on your purchase of our instant shelter. This unit is a combination of excellent manufacturing and design. It is comprised of a rigid frame and a durable cover. For easy assembly, we have marked all the parts with codes, with proper installation, use and maintenance, your unit will provide many years of good and suitable service.

### Tools required

The following hand tool will be needed for proper Installation of your new building:

12mm,14mm, and 17mm Open End Wrenches,

12mm, 14mm, 17mm Sockets or Box Wrench,

Large Flat Head Screwdriver,

2lb maul or Sledgehammer

4 Foot Level 14' Step Ladder

Stake &String for aligning Base Plates &Frame

### Assembly procedure

1. Prepare location and place all unit boxes near location sight. Perform an inventory check before beginning, to be certain all components are available for installation.
2. Secure base plate flanges to base surface.
3. Assemble every group of arch.
4. Begin frame assembly with front end arch, first interior arch, purlins, etc.
5. Add to assemble other groups of arches.
6. Install main cover over frame.
7. Install end cover over end panels.

**Read all the detailed instructions and notices in the following assembly instructions!**

## Maintenance and care

Annually or more often, the unit should be completely inspected internally and externally to make certain the unit remains properly installed and secured. Particular attention should be paid to:

**Hardware-**check all carriage bolts and hardware connectors to be certain they are in place and tightened.

**Weather trends,** the unit will strain against the base plate flange under windy conditions, pegs hardware, connection to frame members should be maintained tight and depth of pegs should be checked to be certain they remain deeply and firmly set.

**Snow Accumulation** -All snow accumulation on the main cover should be removed as soon as possible. Tap the main cover from the inside with a broom or soft brush to clear cover.

**Main Cover Lacing-**the poly rope that secures the main cover to the bottom rail of the frame assembly should be checked, and adjusted as needed. The tension on the main cover should be uniform from end and side to side. Rope ends must be tied off onto the frame members at the ends on each side.

**Cleaning** -cover and doors can be cleaned with a mixture of light detergent and water. A soft bristle brush with the mixture can be used to loosen any hard dirt, mold, or buildup on the cover. After cleansing, the cover should be rinsed thoroughly to avoid any chemical reaction from residual detergent. Allowing dirt and debris to sit on cover over an extended time will damage cover irreparably.

**Severe Weather-**in preparation for inclement weather, completely secure the door of your buildings portable building. Allowing wind to enter end lifts the

**Thanks again for choosing this quality product. The following is the detailed assembly instructions for you starting the assembly.**

Part Code	Description	Quantity
1	Top rood tube	7
2	Roof curving tube	10
2A	Roof curving tube in the front and back panel	4
3	Roof curving tube at shoulder height	10
3A	Tube in the front and back panel	4
4	Sidewall tube	14
5L	Base flange in left corner	2
5R	Base flange in right corner	2
6L	Base flange for left sidewall	5
6R	Base flange for right sidewall	5
7	Base flange for standing legs in the front panel	4
8	Upper vertical tube for front door	4
9	Lower vertical tube for front door	4
10	Beam for the side front panel	4
11	Door beam	2sets
12	Bottom tensioning tube of front and back cover	4
13	Slanting support tube	8
13A	Tube clip for slanting support tube	16
14	Tensioning tube	2sets
15	Dropping tube for the door	2sets
16	Steel peg	30
17	Horizontal tube	64
18	Tie down ratchet	14
19	Hexagon bolt M10×75	204
19A	Hexagon bolt M14×30	58
20	Carriage boltM10×85	40
21	Hexagon bolt M10×85	10
22	Hexagon bolt M10×30	26
23	Hexagon bolt M10×40	4
24	Plastic cap	16
25	pulley	2sets
26	Roof cover	1
27	Cover for front and back panel	2
28	Rope for fastening the roof cover, the door cover and the front&back cover	13
29	Rope for door	4
30	Band for tie down ratchet	14
31	Steel wire for side wall and turnbuckle	8
31A	Steel wire for roof and turnbuckle	16
31B	Steel wire connect with plate	8
31C	Steel wire connect with plate	16
32	Felt	42

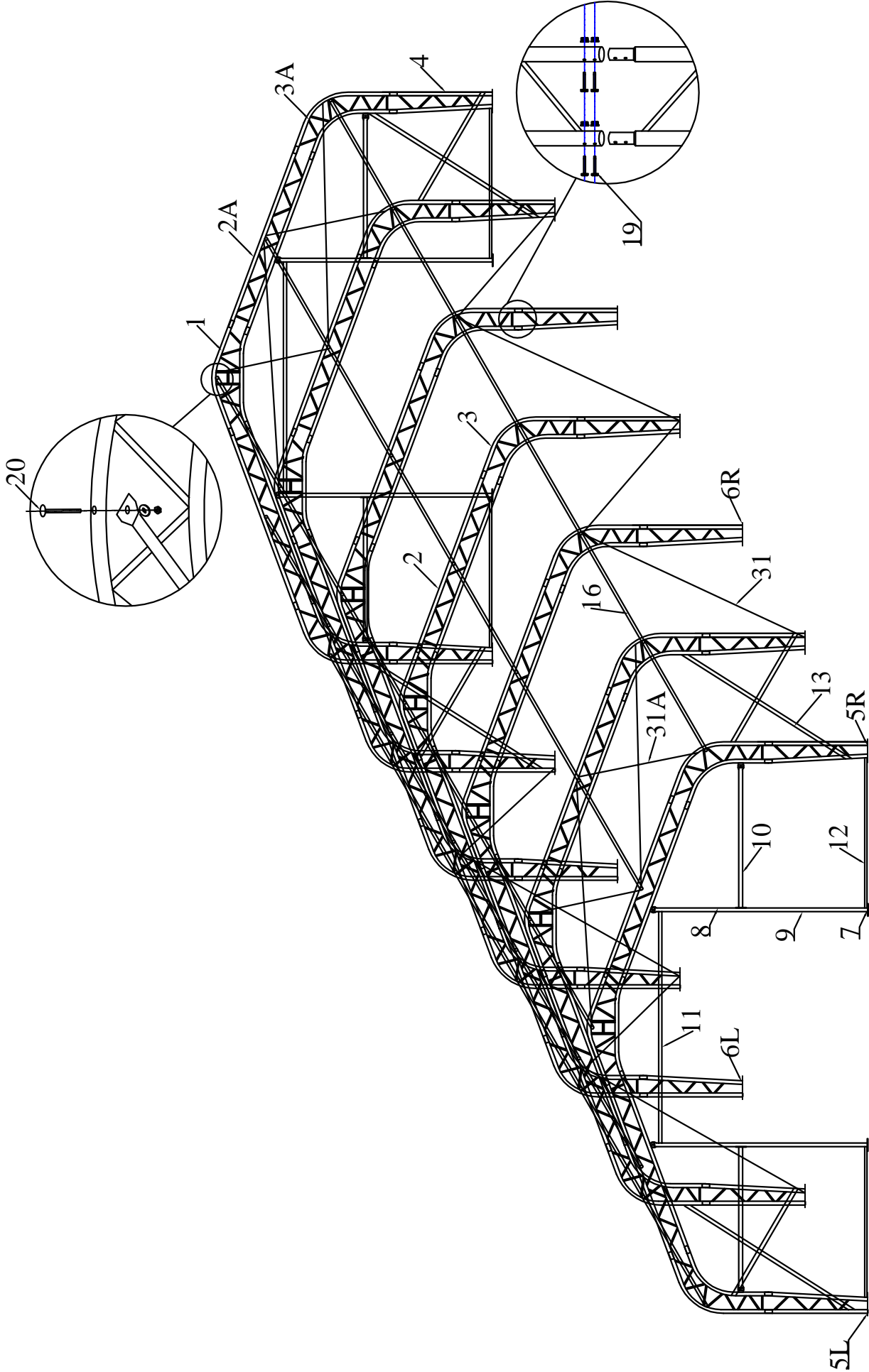

Figure 1  
 Sketch of Model 306015T Size: W9. 15\*L18. 3\*H4.5M

**Step #1 --ARCH ASSEMBLY**

Assemble ALL the arches including the base plates, and LAY them on the ground first. DO NOT erect them until you finish all the arches assembly. Each arches consist of:

One Top roof tube (Part # 1), Two Roof curving tube (Part # 2/2A), Two Roof curving tube at shoulder height (Part # 3/3A), Two Sidewall tube (Part # 4), Two Base plates (Part #5L/5R/6L/6R).

Connect the arches by Using the hexagon bolts with washers and nuts(part #19) through predrilled holes in frame members.

NOTE: Please notice that the part code of the arch sections. The sections of middle,front and back arches are not the same. Check with the Part List and the Sketch Figure.

NOTE: Please use the blanket(part #32) at each joint of connection of arches(except the two joints at bottom).

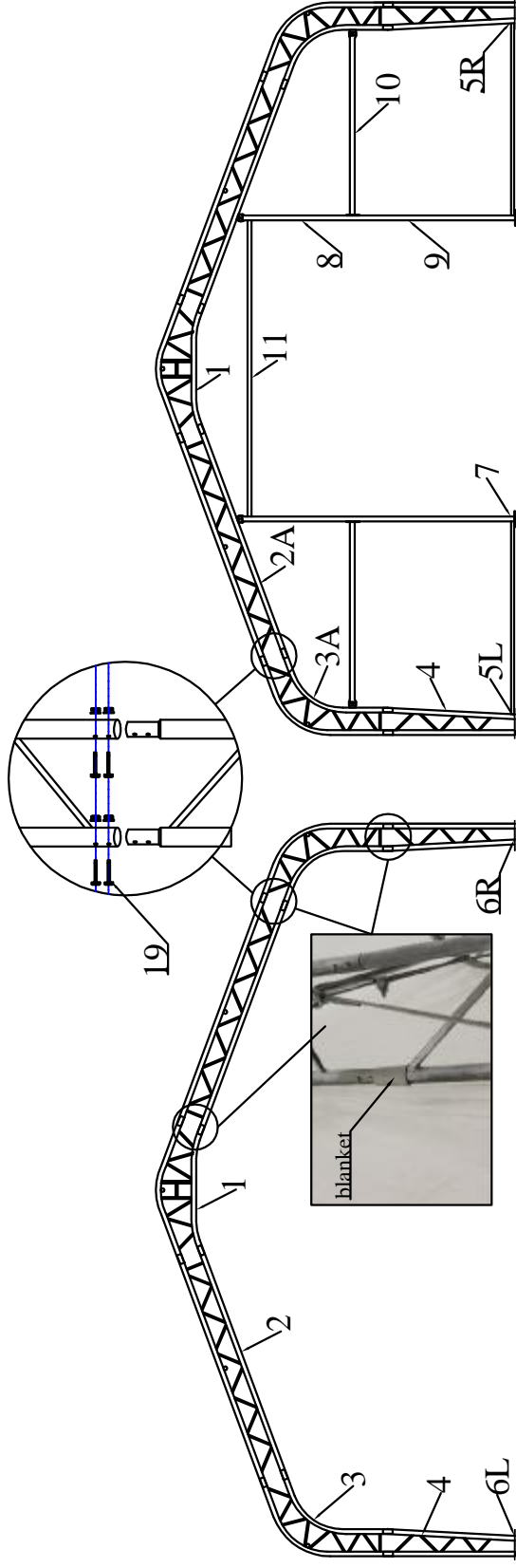

Figure 3 Front and Back Panel Arch

Figure 2 The middle arch

### Step #2 --ERECTING ARCHES

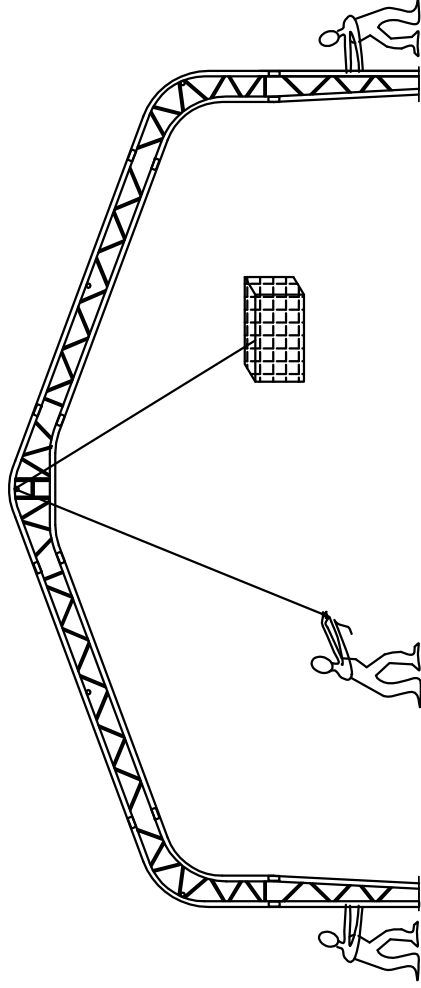

Figure 4 Erecting the Arch

As figure 4 shows, erecting the front arch by using ropes, tie and secure the rope on some heavy object to secure the arch standing temporarily. Then secure the base plates to the ground by using stake pegs(part #24).

### Step #3 --Assembling Roof Purlins

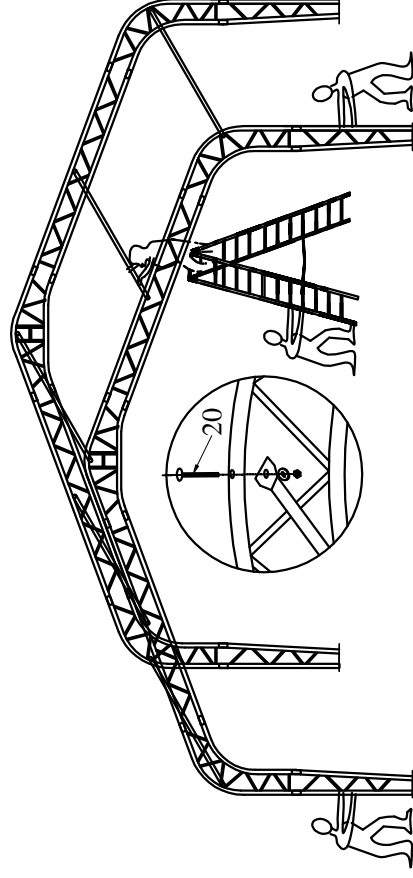
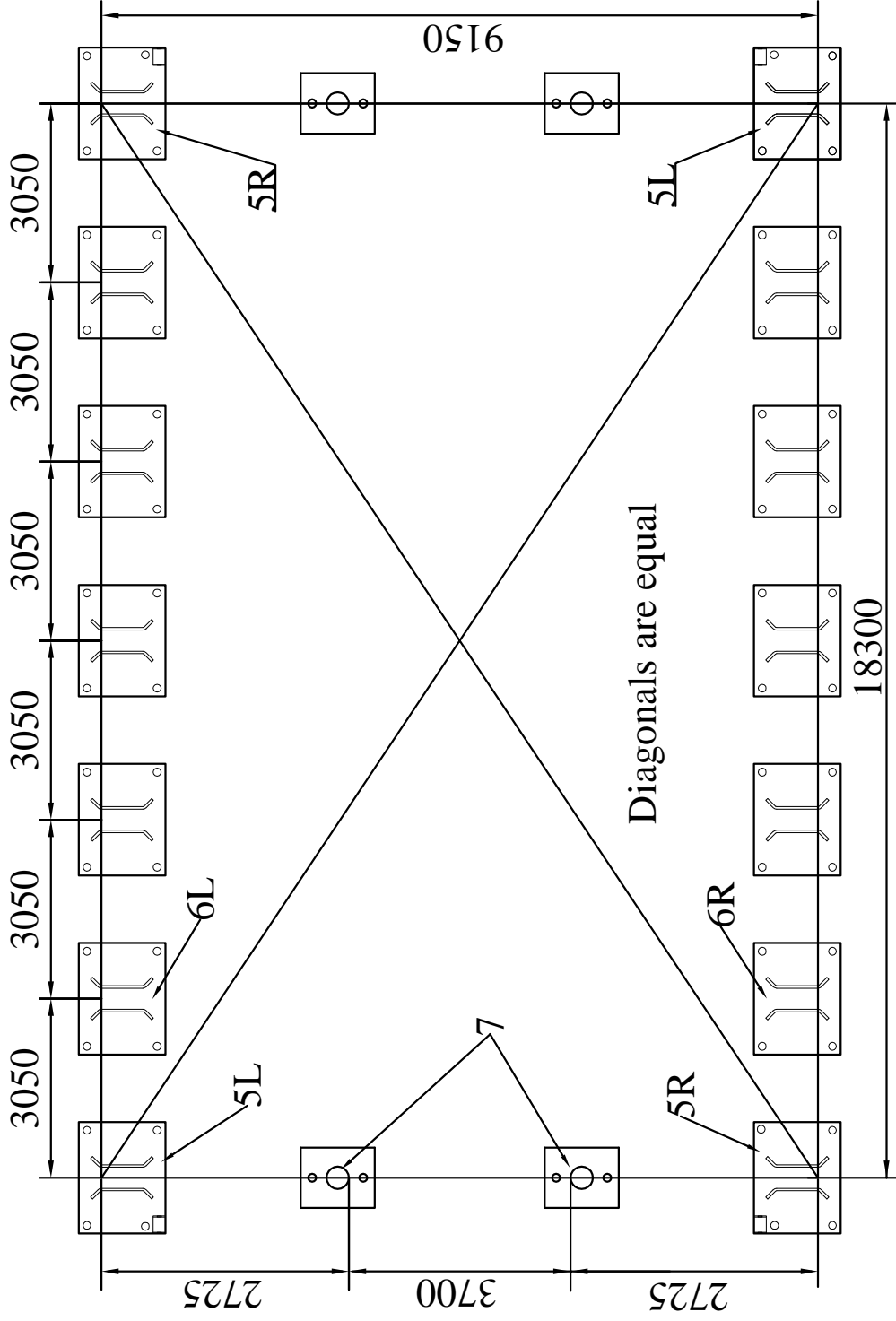

Figure 5

Immediately after erecting the front arch, erect the 2nd arch in the same way. Then connect the two erected arches using Roof Purlin Tubes as figure 5 shows. Secure the Roof Purlin tubes into place using carriage bolts and nuts (part #20).

**Figure 6 Position of Base Flanges**



The Shelter must be secured to a firm surface that can receive and retain pegs firmly in position. The shelter should be installed on FIRM GROUND, not on SWAMP, SOFT/WET GROUND. The Base Flanges must be secured so they cannot be moved.



## Step #4 --WIND STABILIZERS CABLES AND TURNBUCKLES

On each side of frame, between the first and last two groups of arches, and on the front&back panel frame, cables with turnbuckle are provided to align and strengthen frame before installing cover. After installing all cables, tighten the turnbuckles slightly to adjust the arches vertically and to add rigidity.

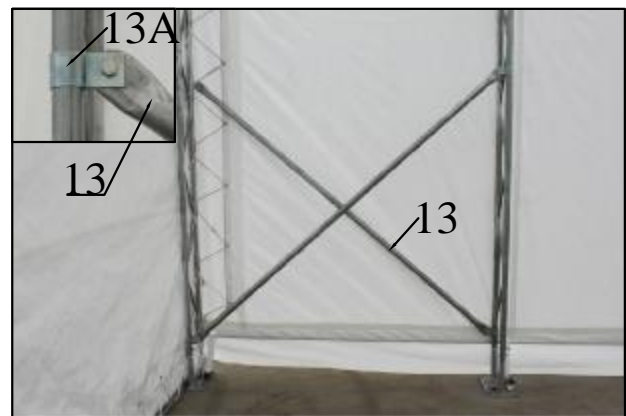
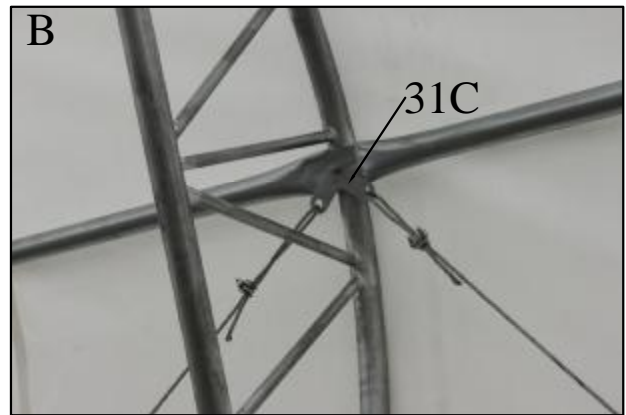
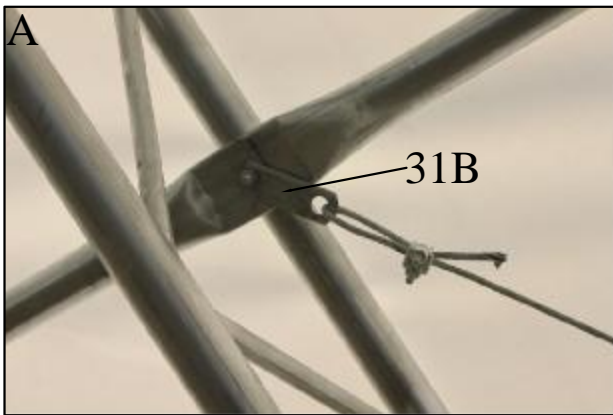
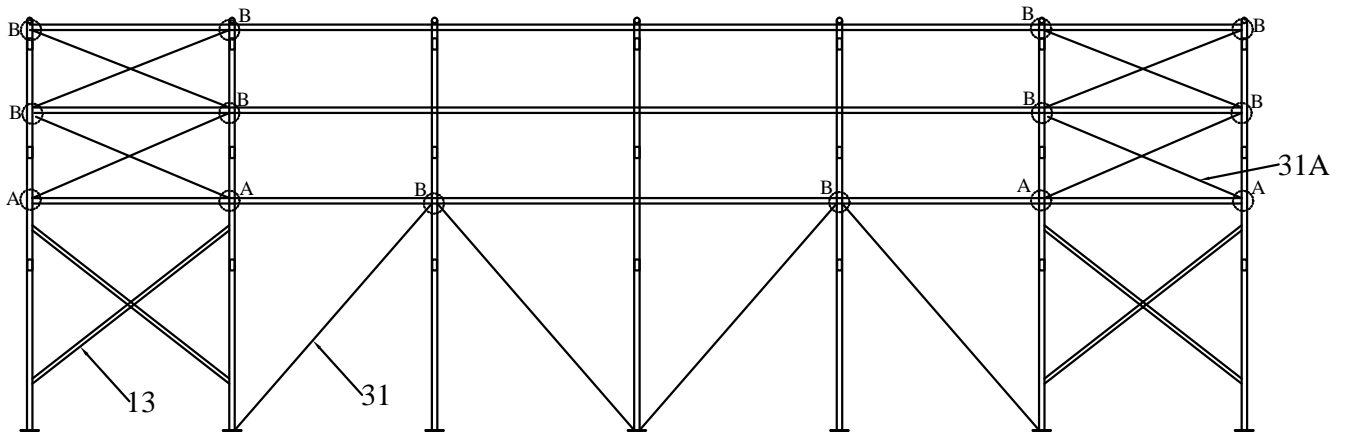

Figure 7 The position of windstabilizers (turnbuckle and cable) at the sidewall.

## ROOF COVER INSTALLATION

### Step #6 --POSITION ROOF COVER

As figure 8 shows, when ready to install Roof Cover, unpack cover and lay parallel to building frame on one side. Cover must be pulled over top of frame assembly without being snagged or stressed on any frame members. Use multiple ropes over top of frame as shown in picture below. Having another person inside frame on a ladder to assist in getting Roof Cover over frame will insure the cover will go on without any damage.

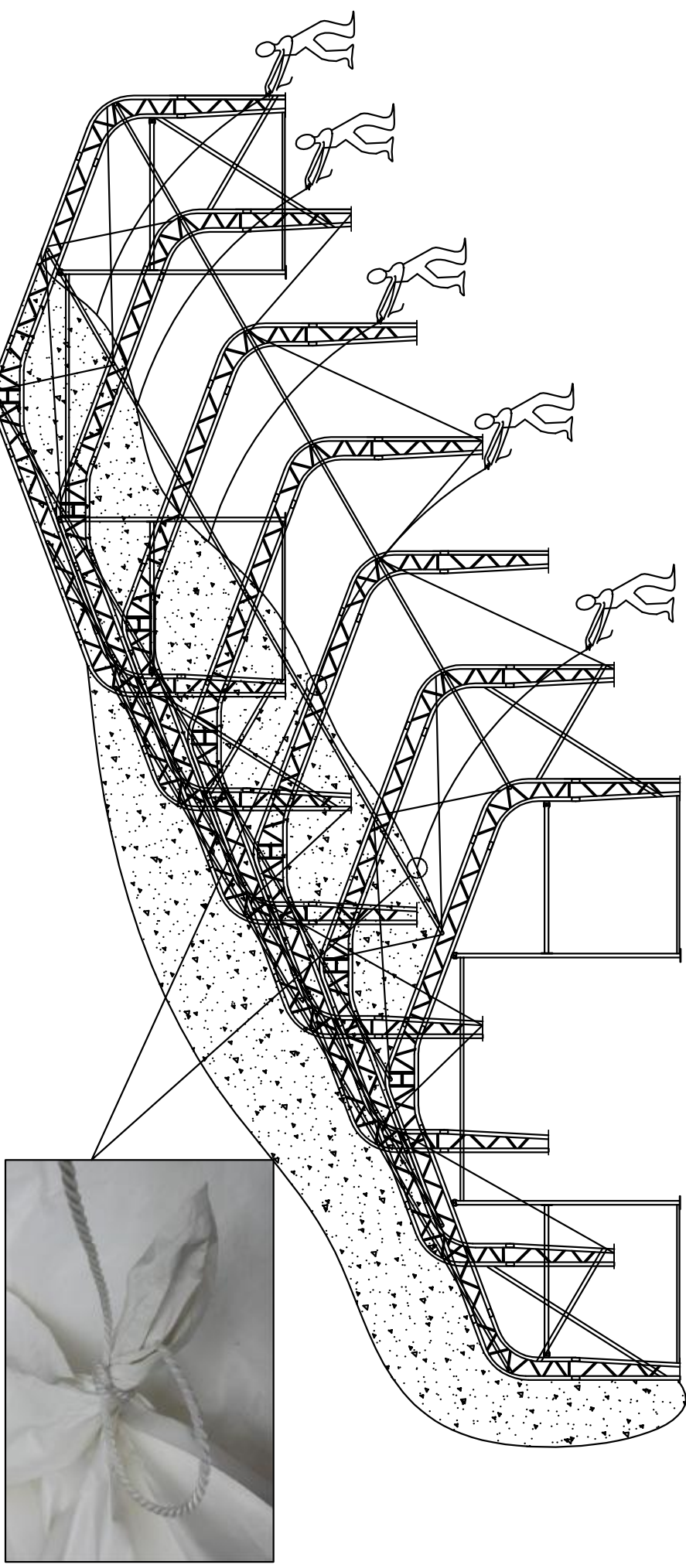
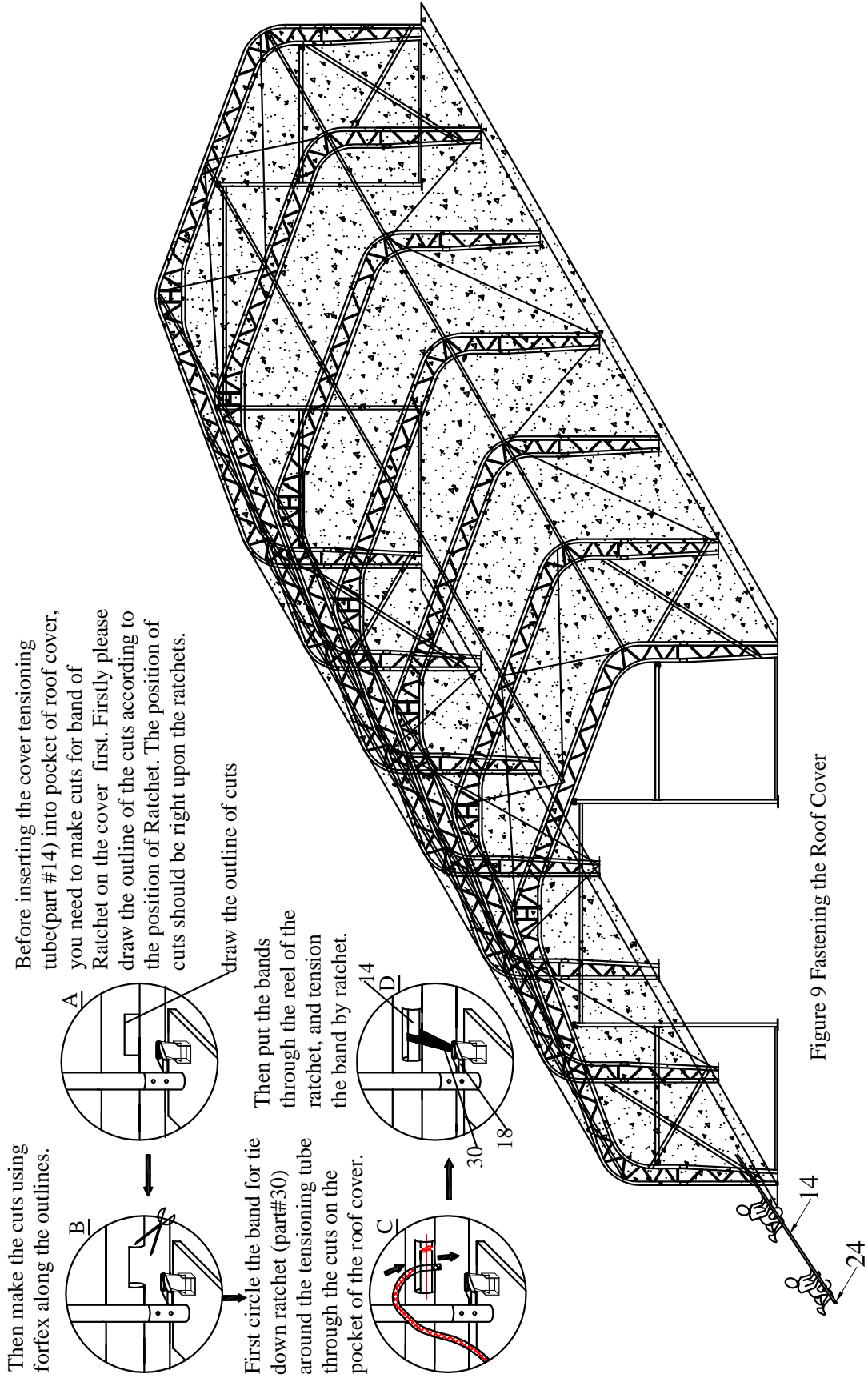

Figure 8 Pull the Roof Cover over the frame evenly

## Step #6 --TENSION COVER ON FRAME FROM SIDE-TO-SIDE

As Figure 9 shows, when Roof Cover is over top of Frame Assembly, insert Cover Tensioning Tubes into pockets along both sides of Roof Cover. Center Roof Cover over Frame assembly both side to side and front to back. Align one side of Roof Cover evenly front to back. Add Band for Tie Down Ratchet at each point along the cover opening, as shown. Put Band for Tie Down Ratchets over Cover Tensioning Tubes at each Base Plate along one side. Bands do not attach to Tensioning Tubes, but loop around and secure at both ends on ratchet.

Next take up slack in tie bands by ratcheting the mechanisms, tightening cover. Evenly adjust ratchets on both sides of roof cover to take wrinkles out of roof cover. **DO NOT** fully tighten cover yet. Leave adequate slack so that cover can also be adjusted front to back in next step.



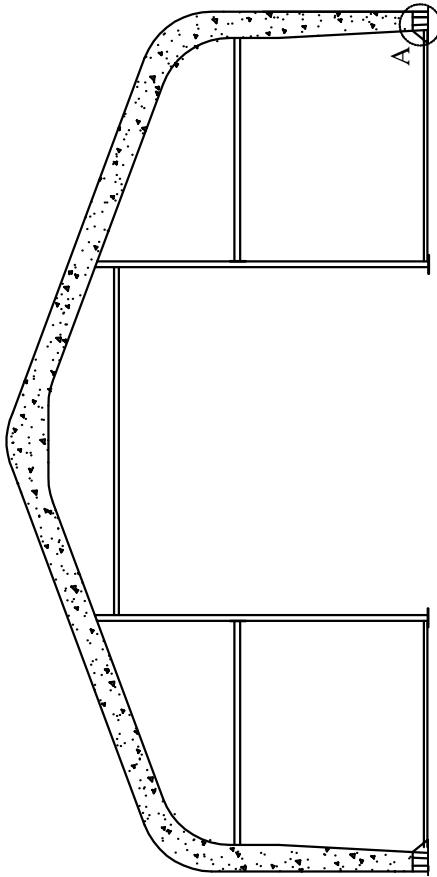

Figure 10 Fastening the two ends of the Roof Cover

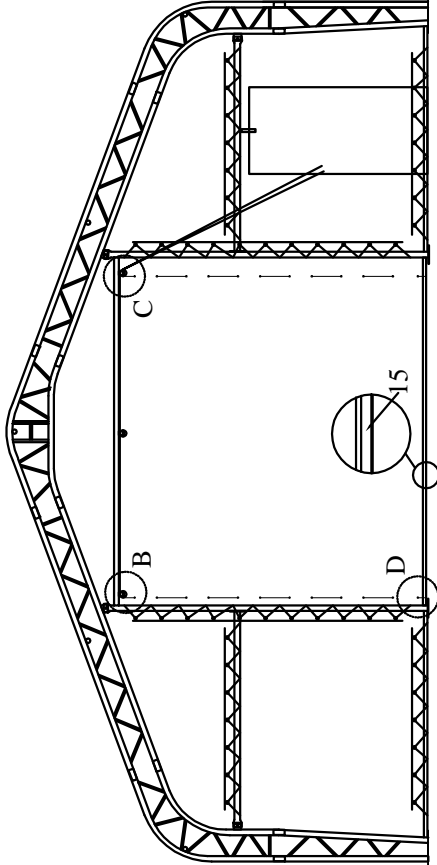

Figure 11 Installation of the Front and Back cover

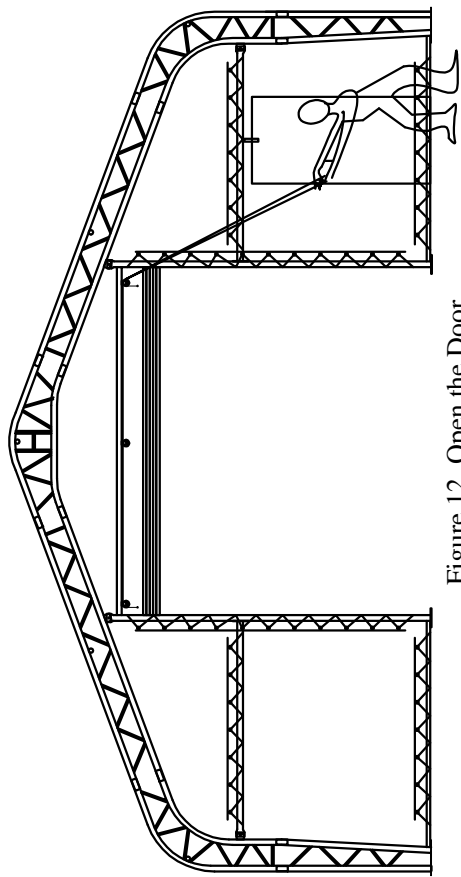
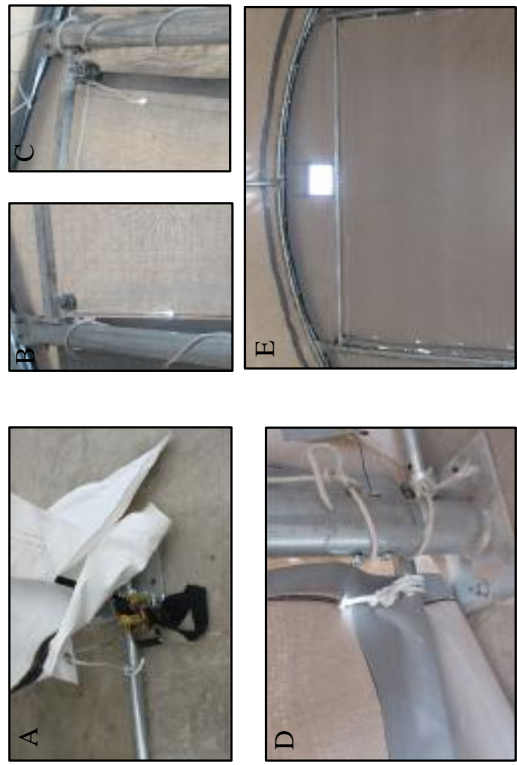

Figure 12 Open the Door



## Step #7 --ASSEMBLE FRONT & REAR COVER

Secure the Front and Back Cover to the arch panel by using the ropes provided.

**Main Cover Edge Tie Off** - Once both Front and Rear Covers are installed, the Roof Cover Edge flap, front and rear, should be tightened and tied off. Begin by pulling the remaining Roof Cover over the Frame arch, so the rope pocket is over the edge of the frame. Tie off the rope that goes through the rope pocket on one side. The rope ties off to the loop that is located on the Base Flange in Corner (6L or 6R). Moving to the other side, begin to pull the rope down. Hold the rope in hand, and push down at the bottom of the rope with a foot. Pull the rope tight, and tie off to the welded hoop on the Base Flange. As you are pulling the edge rope, it will be necessary to adjust the excess material that will collect along the rope packet. Adjust the material so that it is not bunched up and it does not pull the roof cover to one side or the other. Once the Front is completed, repeat the process on the Rear flap of the Roof Cover.